

Michigan Land Use Guidelines for Siting Wind Energy Systems

*Michael Klepinger, Extension Specialist
Michigan State University*



Michigan Land Use Guidelines for Siting Wind Energy Systems

As public interest in renewable energy increases, planning and zoning for wind power are beginning to come of age in Michigan. Publication of new wind potential maps in 2004 helped fuel an increase in landowner interest in wind energy across the state (USDOE, 2004). Wind power companies are prospecting for new sites among landowners, and when landowners inquire at their local government offices about local permits, they often discover the rules are unclear. Very few Michigan jurisdictions have wind system siting laws on their books.

Although only three commercial-scale turbines were operating in the state at the end of 2006, an additional 52 turbines were reportedly under construction or proposed during the year (Sarver, 2006; AWEA, 2006). Some neighbors of these wind development projects are voicing concerns to township, city and county officials. The most common concerns are about tower heights, tower setbacks, wildlife impacts, blade shadow flicker and noise. These topics, and related scientific studies, are addressed in this bulletin.

Communities that proactively plan for wind turbines and carefully develop regulations for their installation will avoid a measure of uncertainty and the unfortunate public discord that sometimes comes along with new land use proposals. (Recall, for example, the spate of cell tower controversies during the 1980s and 1990s.) All local officials are advised to consider adopting planning policies and regulations before an energy facility siting application is received.

Guidelines for siting wind energy systems were released in December 2005 by the Michigan Energy Office in the Department of Labor and Economic Growth (DLEG). The DLEG guidelines are titled “Michigan Siting Guidelines for Wind Energy Systems,” and they are now available online. The new guidelines are meant to help local officials strike a balance between the need for clean, renewable energy resources and a local government’s responsibility to protect the public health, safety and welfare. They present background commentary and suggested zoning language for local governments.

This bulletin describes the most important provisions of the new guidelines and how they suggest handling the most common concerns of neighbors. It looks at the science behind the guidelines and provides a glossary and references for further reading. It concludes with a short list of Michigan communities that have adopted local planning and zoning laws about wind system siting.

Growing supply and demand for renewable energy

According to the U.S. Department of Energy, the Federal Energy Regulatory Commission and other authorities, the cost of the fossil fuels most commonly used to generate electricity continues to rise. The average end-user price of electricity in the United States was 8 cents per kilowatt hour (kWh) in 2005 (EIA, 2006a).

Since the early 1980s, the price of wind-generated electricity has dropped more than tenfold—from about 40 cents per kWh in 1980 to about 4 cents to 6 cents in 2005 (Aabakken, 2005). The Federal Energy Information Administration assumes in its most recent forecast that current (wholesale-level equivalent) costs from coal and natural gas generation range from 4 cents to 5 cents per kWh, which suggests that recent wind power prices can be competitive with the most common electricity fuels (EIA, 2006b). If the United States were to impose so-called carbon taxes on fossil fuel-based facilities, as is done in other countries, wind-generated electricity would become relatively cheaper (Duke, 2006).

Now that wind power is competitively priced, it offers real advantages over conventional sources because it generates energy without using fossil fuel. Wind energy production is immune from fuel price spikes caused by natural disasters and by political instability. Wind provides a hedge against rising energy costs.

A study released in 2006 by the Rand Corporation states, “Wind is the fastest growing form of renewable energy in the United States and the only source of

renewable energy that is currently cost-competitive in multiple markets with conventional electricity sources.” In 2005, wind industry capacity in the United States expanded by about one-third (Rand, 2006; EIA, 2006b).

According to industry sources, 2,454 megawatts (MW) of new generating capacity was installed in 2006, an investment of approximately \$4 billion. (One megawatt of wind power produces enough electricity to serve 250 to 300 homes on average each day.) These new wind farms boosted cumulative U.S. installed wind energy capacity by 27% in 2006 to 11,603 MW (AWEA, 2007).

Benefits of renewable energy

Renewable energy is part of the current conversation around Michigan. Proponents note that electricity generated by wind energy systems will reduce air pollution and help slow global climate change. It will increase the fuel diversity and security of our electric system, reduce the impacts of coal mining, and relieve pressure to extract oil and gas from fragile environments. It will provide a hedge against increases in the price of fossil fuels while reducing the need to build new central power plants. And industrial or agricultural activity can continue in and around wind tower sites. Many people see renewable energy, particularly wind energy, as a substantial part of Michigan’s diversified energy supply in the future.

Fossil fuel-based electricity generation is responsible for 36% of carbon dioxide pollution, 64% of sulfur dioxide pollution and 26% of nitrogen oxide pollution in the United States (EIA, 2005). Coal-burning power plants are the largest human-caused source of mercury emissions to the air, accounting for over 40 percent of all domestic human-caused mercury emissions (USEPA, 2006). Although most of Michigan’s electricity supply is currently derived from burning coal in plants built in previous decades, there are now viable alternatives.

Wind energy is also the fastest growing source of electricity in the world. Approximately 1,650 new wind turbines were installed in the United States during 2005. Although leasing arrangements vary widely, the American Wind Energy Association estimate for income to a landowner from a single utility-scale turbine (1.5 MW) is about \$3,000 a year. Many landowners (particularly farmers) are currently considering lease offers from wind development companies.

Despite the many attractions of wind energy, proposals to install new wind generation towers and facilities can stir up controversy in community planning and zoning meetings (as local officials know is true with any type of proposed development).

Proponents and opponents: a special note about scientific facts and issue advocacy.

It is sometimes difficult to know whom to believe in a land use controversy. Proponents and opponents alike can be very convincing — and sometimes they misuse scientific data.

Sometimes an issue revolves around personal opinion or personal taste and aesthetics; sometimes there isn’t one “right” answer. Most local officials are not trained scientists, but they are nevertheless asked to decide wind power siting issues grounded in scientific studies.

Proponents might say:

1. Wind turbines are visually interesting.
2. Wind turbines are quiet.
3. Wind power does not pollute.
4. Wind power increases national security.
5. Wind turbines leave a small footprint.
6. Wind power can supplement other sources.
7. Wind power is never going to rise in cost.

Opponents might say:

1. Wind turbines spoil the scenery.
2. Wind turbines are noisy.
3. Wind turbines kill a lot of birds.
4. Wind cannot totally replace other sources.
5. Wind turbine blades are dangerous.
6. Wind power is intermittent.
7. Wind power costs more than coal.

Local officials can expect some or all of these difficult data interpretation issues to arise, and it is a very challenging job. Despite these challenges, a thoughtful review of the science, engineering and field experience behind wind energy is required of local land use officials who want to take a fair and objective look at the issues.

Publications and Web sites of proponent organizations and opponent groups often refer to scientific research. Unfortunately, references are sometimes taken out of context, and they are sometimes misused. The sidebar at right is a recent example of how one scientific paper was used. Opponents and proponents both erred (in their favor) when making a case for a decision on the size of a property line setback. Neighbors raised the possibility of ice throw.

In this example, the proponent claims the Morgan study says the probability of being hit by ice throw is just as low as the probability of being hit by lightning. But anyone who takes the time to read Morgan's study can see the inaccuracy of the proponent's claim. Morgan does not say this.

Also in this example, the opponent claims that industry guidelines (not just one scientist) recommend a very high risk protection level — setbacks should be large enough so that the chance of being hit by ice remains as low as the probability of being hit by lightning. Morgan does not say this, either.

Reading Morgan's scientific paper and the scientific papers he cites makes it clear that there are no guidelines agreed upon by the industry. How can these advocates make such claims? It is fair to say that neither the opponent's nor the proponent's use of Morgan's statement is based on an objective reading of the statement.

From this example, we can see why planners and local officials must carefully investigate any controversy. Independent third-party information is required. Officials must ask: What do we know to be true and what further research is needed on the issue at hand? The Michigan Siting Guidelines for Wind Energy Systems provide a good foundation for local decision makers. The guidelines were written with deliberation and substantial input from a group of Michigan stakeholders and experts in the field.

Original wording of the statement in a scientific article:

"The level of risk which is acceptable should be determined. This is subject to case-specific factors such as ease of access, however a suitable level may be 10^{-6} strikes/m²/year which is the typical probability of lightning strike in the UK" (Morgan, 1998, citing MacQueen).

Reference as used by opponent:

"The wind industry's authoritative ice throw guidelines recommend an ice throw risk of 10^{-6} – or one strike per million square meters per year. At this risk level, a minimum ice throw safety setback for ...an 82 meter rotor diameter wind turbine in heavy icing conditions...is 656 meters (2,152 feet)" (citing Morgan, 1998).

Reference as used by proponent:

"The paper concludes that the risk of anything or anyone being hit by ice from a wind turbine is ' 10^{-6} strikes/m²/year, which is the typical probability of being hit by a lightning strike in the UK'" (citing Morgan, 1998)

How the original statement by Morgan is used in this MSUE publication:

The author is stating that an acceptable risk level has not yet been determined and *he merely offers a level that may be suitable*. And though that is somewhat interesting, it does not make the case for either side of the setback issue. (It also happens that Morgan's article referenced a 1983 study concerning rotor blade fragmentation, not setbacks or the physics of ice throw.)

What the Michigan guidelines have to offer

As a starting point, the guidelines suggest that local governments should adopt different requirements for systems constructed for on-site use and for larger systems built to supply the utility grid. They suggest that communities place personal systems in one class and utility-scale systems in another class of land use.

The guidelines suggest placing large projects, referred to as “Utility Grid” systems, into a special land use permit process of site plan review. They recommend that utility-scale site plan requirements should include a map of:

- The project area boundaries.
- The location, height and dimensions of all existing and proposed structures and fencing.
- The location, grades, dimensions of all temporary and permanent roads.
- Existing topography.
- Water bodies and wetlands.
- All new aboveground infrastructure related to the project.

Furthermore, there are utility grid system provisions for liability insurance, regulatory compliance, preconstruction environmental studies, visual impact simulations and a shadow flicker analysis. These are recommended in addition to addressing setbacks and sound levels for smaller, so called, “On Site Use” wind systems (described below). A decommissioning plan and a complaint resolution plan are also suggested for larger utility grid proposals. For large systems, the guidelines refer the reader to the Michigan Airport Zoning Act (Public Act 23 of 1950, MCL 259.431 et seq.) and the Michigan Tall Structures Act (Public Act 259 of 1959, MCL 259.481 et seq.).

Small Systems: Two Key Concerns

Small “On Site Use” wind systems are defined in the DLEG guidelines as systems “intended to primarily serve the needs of the consumer” on whose property they are constructed. There are two primary concerns for on-site systems in the guidelines: setbacks and sound.

First, the recommended setback between a consumer’s wind energy system and property lines is to be a minimum of 1½ times the height of the wind tower. Height should be measured from the base of the tower to the top of one of the blades in a vertical position. And secondly, the guidelines suggest that, to handle noise issues, small wind energy systems should be metered and proven not to exceed 55 decibels on the “A” scale (dB[A]) at the property line. (However, if the ambient sound pressure level exceeds 55 dB[A], the guideline standard is the ambient level dB[A] plus 5 dB[A]. Local officials should use caution here. See “Noise levels” on page 9).

A few more on-site small system safety concerns are addressed in the Michigan guidelines. To protect passers-by, it is recommended that the minimum vertical blade tip clearance from ground level should be 20 feet (for a wind energy system employing a horizontal axis rotor — vertical axis generators are currently quite rare). In addition, the guidelines suggest lightning protection and an automatic braking or governing requirement to prevent uncontrolled rotation or overspeeding. And if a tower is supported by guy wires, the wires should be clearly visible to a height of at least 6 feet above the ground.

The guidelines recommend that on-site use wind energy systems should be classified as a “permitted use” if the tower proposed is 20 meters tall or less. As such, a small system would be allowed as a use by right within any zoning district selected by local officials. Towers more than 20 meters in height, however, whether they are declared to be for personal use or are to provide utility-scale power, should be classified as “special use” structures. So, the height of a system determines the amount of information the applicant must provide. Smaller “permitted use” system approvals require less information than larger “special use” system approvals.

If a personal-use tower is to be permitted, a list of application provisions is suggested in the guidelines. These include applicant identification; a site plan; documentation that sound pressure levels, construction codes, tower integrity, interconnection (if applicable) and safety requirements have been met; and proof of the applicant’s public liability insurance.

Neighbor concerns with utility-scale systems: issues for local officials

A number of issues are at hand when large-scale wind systems or wind farms are proposed. The following sections provide a description of how the guidelines address stakeholder concerns about siting larger utility-scale wind systems and what the available scientific evidence says about the issues.

Tower height

The DLEG guidelines do not suggest setting a maximum height for wind systems. This is because, at least in part, rapid innovations in technology dictate that individual installation requirements will change (Sarver, 2006). But the guidelines do suggest that it is prudent for local government officials to consider the proposed height and then classify the development accordingly.

Regulating the height of structures is nothing new in Michigan communities. Michigan law specifically allows regulation of building heights. It follows, therefore, that wind generator towers, which are “built structures,” should be subjected to the same legal treatment as any other building.

Building heights are in some cases regulated because of the size of local fire and emergency equipment (public safety). In others, heights are limited because of aesthetic or cultural concerns (public welfare).

Washington, D.C., for example, restricts building heights to “the width of the street plus 20 feet” (which, incidentally, preserves the record local height of the Washington Monument). In Madison, Wisconsin, city law limits the height of buildings within 1 mile of the Wisconsin State Capitol (Madison General Ordinances, 2002). Michigan communities are given quite a bit of discretion when regulating structure heights, so long as there is a valid public safety purpose or public welfare purpose.

As discussed in the next section, the guidelines establish a direct relationship between tower heights and property line setbacks to ensure public safety.

Setbacks

Property line setbacks for primary structures such as a house or a store and for accessory structures such as a residential garage or storage shed are often provided for in local zoning codes and regulations. And though setback provisions are sometimes enforced to preserve airspace or views for the welfare of the public, the genesis of setback regulation lies in public safety. This is in large part due to the Great Fire of London in 1666 and subsequent experience here in the United States.

Access between buildings in crowded urban areas is particularly important to fire suppression. Setbacks are important for a number of reasons.

When applied to a wind power development, property line setbacks address two potential issues of public safety: equipment failure and ice throw or ice shedding.

There are no recorded injuries to passers-by or neighbors from wind energy systems (Sipe, 2005). As many as 25 people have been killed while installing or servicing wind turbines. The literature indicates that only one non-industry person has ever been killed by a wind power installation — a parachutist (Sipe, 2006). Wind tower or turbine structural failures rarely occur, but in fact they have occurred. It is prudent, therefore, to require a horizontal setback at least equal to the vertical height of the system in case of a tower collapse. With this simple provision in place, damage to neighboring property could be avoided in the event of a tower collapse.

Cold-weather icing of generator blades and turbine components is a possibility in Michigan, as it is in parts of Europe, where reliable independent studies have been done on the dangers of falling ice. Insurance industry sources indicate that no liability or injury claims have been incurred because of icing in either Europe or the United States (Fox, 2004).

Why do the guidelines recommend a setback based on system height?

It is true that, with any type of tower or building, large pieces of ice can dislodge and fall to the ground. This is called ice shedding or ice sloughing. Wind energy systems do not present any new or unusual risk from ice sloughing when they are standing still — the force of gravity is in control. Shedding can occur on a calm, sunny day. Setback provisions to protect from ice sloughing could be the same for wind systems as those used for other structures.

Some scientists (Seifert et al., 2003) recommend a simple formula to protect the public during the few days each year that heavy icing occurs:

$$\text{setback} = \text{hub height} + \text{blade diameter} \times 150\%$$

Spinning rotor blades do present a certain amount of risk of ice throw because of the centrifugal force of the rapidly spinning blades. Proponents suggest the risk is negligible — very thin ice sheets and small ice particles have never hurt anyone.

Opponents, on the other hand, have suggested that all risk must be considered. It has been suggested that perhaps protection from ice throw should be based on the statistical risk of being struck by lightning (Morgan, 1998).

Why not just use a scientifically calculated, model-based setback distance?

Modeling ice throw will take us only so far. Though we really cannot make progress in today's world without projections and models, neither will models provide all the answers. Because there are so many variables involved, all models include fundamental assumptions about what will occur. And no matter how carefully a model is crafted, the assumptions in a model will not satisfy all opponents or proponents.

So, ultimately, local officials have to decide for themselves. How large is too large? It is true in system modeling that the larger the horizontal setback requirement, the safer. What distance is really needed to protect neighbors from ice throw?



Fortunately, experience shows that property damage or personal injury from ice throw is very limited. It is a matter of basic physics that ice buildup significantly and negatively affects the aerodynamics of windfoils. Ice-laden blades do not spin very fast, if they spin at all. The range of ice throw (distance from the tower) is determined largely by blade speed.

Scientific models and practical experience both tell us that the greatest risks from ice or any other falling material are within one blade diameter of the tower base (MacQueen, 1983; Fox, 2004). Local officials can rely on the laws of physics — small particles and thin sheets of ice are more likely than large, heavy chunks to be thrown from rapidly spinning blades. Off-site risks appear to be quite low. There are no recorded injuries to passersby or neighbors from wind energy systems.

Clearly, ice fall is not the only perceived safety issue with wind energy systems. Towers have collapsed, and large pieces of blades have fallen to the ground. There have been turbine fires. Small components — for example, nuts and bolts — have fallen to earth. But, as with ice danger, there is no record of anyone being hurt off-site because of system component failure. Evidence of damage to off-site property could be called negligible.

So, local officials are advised to require property line setbacks for turbine towers, and a horizontal distance of 1 to 1½ times the system height is recommended in the new DLEG guidelines as a good benchmark to protect neighboring property.

Setbacks affect the developer's bottom line

When local officials decide how large the setback must be, they are also determining the total number of wind generators a landowner can install. This affects the economic viability of developing wind power projects on each site and in the community as a whole.

In addition to legal setback requirements, wind developers must calculate how closely turbines can be located to one another within the setback area. This spacing is necessary because of the turbulence or "wake" each turbine creates. Wind developers often base their calculation of turbine spacing on the size of the rotor diameter, in part. Depending on prevailing winds and land features, a distance of three, five or even 10 rotor diameters between turbines might be required to maximize the efficiency of the installation.

For example, a required setback from property lines "equal to the system height" on the illustrated rectangular 80 acre parcel allows the installation of as many as five turbines. A larger setback — in the second example it is "equal to 1.5 times system height" — allows three turbines. An even larger setback — the third example illustrates a setback requirement "equal to 2 times system height" — excludes placement of any turbines on the rectangular 80 acres.

There are more issues than safety, profitability and economic development to consider when local officials decide on a setback requirement. Setbacks affect the character of a community because they affect the overall aesthetic experience of residents and visitors to the area. All setback provisions should be based in the community plan. The setback distance to neighboring property also affects the potential for noise pollution and light strobing or shadow flicker that neighbors will experience.

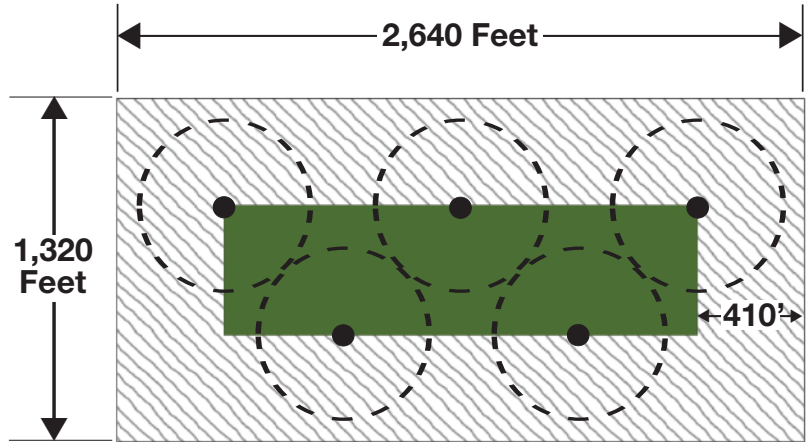

Five turbines on 80 acres with setback of 410 feet.

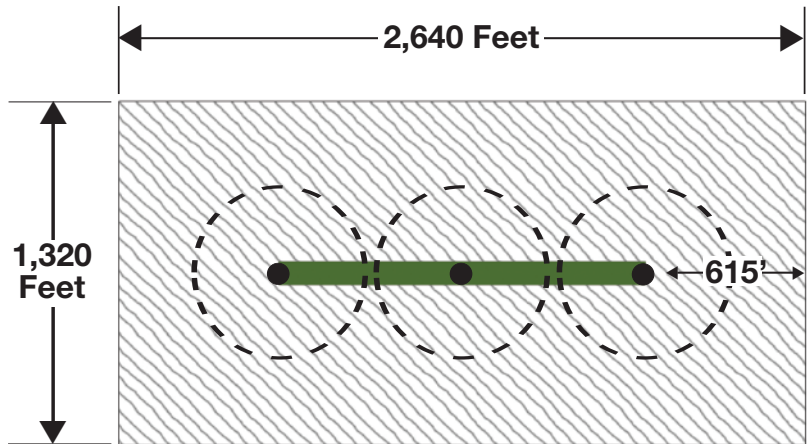

Three turbines on 80 acres with setback of 615 feet.

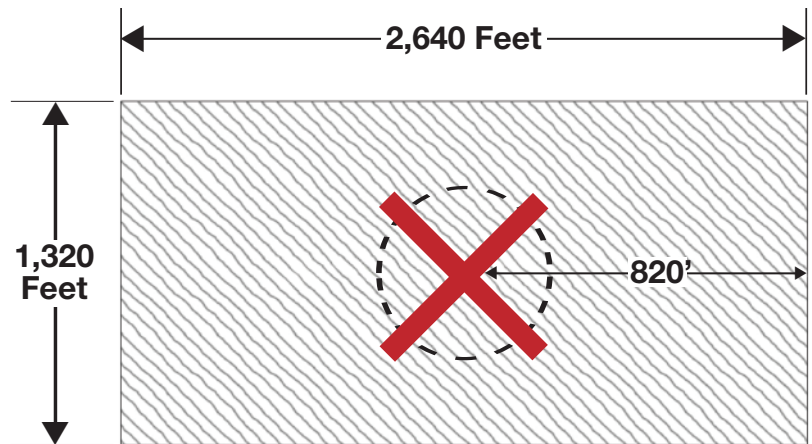

No turbines on 80 acres with setback of 820 feet.

* These setback illustrations assume minimal tower spacing of three rotor diameters or 690 feet and system height of 410 feet on a rectangular 80-acre parcel. The same assumptions on a square 160-acre parcel would allow installations of 11, nine and five turbines, respectively.

Noise levels

At higher wind speeds, the ambient sound of rushing wind tends to mask turbine sounds. Wind machines have three sources of sound: the turbine blades passing through the air, the spinning generator and the moving gears. Regardless of the source, local government is responsible for setting local rules about excessive sound or noise. The authors of the new guidelines considered many aspects of wind system sounds and then presented their recommendations, based on potential long-term health effects, potential interference with speech and other activities, and potential sleep disturbance. These issues are sometimes raised by neighbors during wind system permitting and siting. Unfortunately, very few scientific studies (related to wind power systems) address these effects.

Field studies are needed to investigate the impact of wind turbines on people living in their vicinity (Pedersen and Wayne, 2004; van den Berg, 2004). This is a new and active area of research. Scientists held the first International Conference on Wind Turbine Noise in Berlin in 2005, and a second international wind turbine noise conference will be held in France in 2007, organized by the Institute of Noise Control Engineering.

Local decision makers currently find themselves in an awkward position — without a scientific basis for their judgments about noise effects. And because noise is generally defined subjectively as “unwanted sound,” scientific studies might never be conclusive. Noise is a subjective judgment — some people enjoy the hum of a turbine. And what is music to some is just noise to others.

Noise issues are complex; many communities have never adopted detailed noise standards. Very few communities have purchased sound level meters to measure noise objectively, and most people do not routinely judge sound in terms of decibels. (One of the best places to learn about sound pressures and decibels is the Australian University of New South Wales Web site, currently at <http://www.phys.unsw.edu.au/~jw/dB.html>.) Although the newest turbines are relatively quiet, all wind turbines emit low frequency, midrange and high frequency sound that can be perceived for some distance.

Sound engineering consultant fees of several hundred or even a few thousand dollars have been incurred in attempts to quantify off-site noise in land use contro-

Communities that do have a noise ordinance usually take a relatively ineffective approach similar to this:

Section 2. Prohibited Noises

A. General Regulation

It shall be unlawful for any person to make, continue or cause to be made or continued any loud, unreasonable, unnecessary or unusual noise or any noise which either annoys, disturbs, injures or endangers the comfort, repose, health, peace or safety of any other person, resident or property owner within the Township.

B. Specific Prohibitions

The following activities and noises are prohibited if they produce clearly audible sound beyond the property line of the property on which they are conducted.

[...more...]

Note that this poor example ordinance uses the subjective standard of “clearly audible” sound. Subjective standards have failed in Michigan courts. The Michigan Wind Siting Guidelines suggest a different approach--using a measurable objective standard rather than a subjective standard. (All local ordinance provisions should be reviewed by a member of the Michigan Bar Association.)

versies with sound level meters. The cost of access to expertise is sometimes a significant barrier to objective judgment.

Although acoustic scientists have adopted a standard that provides a uniform methodology to ensure consistency and accuracy in the measurement and analysis of sound, there are no generally agreed upon standards for how to apply the measurements when regulating wind system noise in a community.

There are no directly applicable federal or state laws. The U.S. Department of Labor Occupational Safety and Health Administration (OSHA) has issued regulations



Most indoor conversation is in the range of 55 to 60 decibels (dB[A]).

COMMON SOUND LEVELS	
	Sound pressure level dB(A)
Threshold of hearing	0
Broadcast studio or rustling leaves	10
Quiet house interior or rural evening	20
Quiet office interior or ticking watch	30
Quiet rural area or theater interior	40
Quiet suburban area	50
Office interior or ordinary conversation	60
Vacuum cleaner ten feet away	70
Passing car ten feet away	80
Passing bus or truck ten feet away	90
Passing subway train ten feet away	100
Night club with band playing	110
Threshold of pain	120

Source: State of Maine TAB #4 Noise, 2000.

for protection of workers in the workplace, but it has no authority to regulate noise off-site. Congress passed the Noise Control Act of 1972 and the Quiet Communities Act of 1978, and although these laws remain in effect today, they are essentially unfunded.

The U.S. Environmental Protection Agency issued an advisory document in 1974 that is still used by state and local governments that have the responsibility to regulate most neighborhood noise (USEPA, 1974). The advisory is also used by sound engineering consultants who advise local government officials. It identifies a 24-hour exposure level of 70 dB(A) as the level of environmental noise that will prevent any measurable hearing loss over a lifetime. Levels of 55 dB(A) outdoors and 45 dB(A) indoors are identified by the EPA as “preventing activity interference and annoyance.” These levels of noise are considered appropriate to permit spoken conversation and other activities such as sleeping, working and recreation (USEPA, 1974).

The EPA levels are not single-event or peak levels. Instead, they represent averages of acoustic energy over periods of time, such as 8 hours or days or years. For example, occasional higher noise levels would be consistent with a 24-hour exposure average of 70 dB(A), so long as a sufficient amount of relative quiet prevails for the remaining period of time (USEPA, 1974).

Acceptable noise levels for various areas are identified by the EPA according to the use of the area. Levels of 45 dB(A) are associated with indoor residential areas, hospitals and schools; a level of 55 dB(A) is identified in the advisory for certain outdoor areas (USEPA, 1974).

In contrast to the EPA advisory on neighborhood noise, the new Michigan wind energy guidelines do not suggest different dB(A) levels for various places (hospitals, schools, etc.) or land use zones. Rather, they suggest that, in most cases, a decibel level of 55 dB(A) measured at the property line should not be exceeded for more than 3 minutes in any hour of the day. Recognizing that some installations will be proposed in areas that already have higher sound levels, they also recommend that, if the ambient sound pressure level exceeds 55 dB(A), the standard should be set as ambient dB(A) plus 5 dB(A).

And finally, as part of the large-scale wind system application process, the applicant is to provide modeling and analysis that will show that the utility grid wind energy system will not exceed the maximum permitted sound pressure levels. After installation of the system, sound pressure level measurements must be done by a qualified third party and submitted in a report as proof of compliance.

Shadow flicker

Shadow flicker is a term used to describe what happens when rotating wind turbine blades come between the viewer and the sun, causing an intermittent shadow. For residents close to wind turbines, shadow flicker can occur under certain circumstances (most notably near sunrise and sunset) and can be annoying when trying to read or watch television (AWEA, 2006b). Screening of neighboring property with plants, awnings or structures is the most common treatment for shadow flicker annoyance. Opponents have raised health concerns, particularly mentioning the idea that shadow flicker might trigger epileptic seizures.* However, there are no documented health affects associated with shadow flicker.

The Michigan Siting Guidelines for Wind Energy Systems suggest utility grid systems should have a shadow flicker analysis submitted as part of the special use permit application package. The analysis must “identify the locations of shadow flicker that may be caused by the project and the expected durations of the flicker at these locations from sunrise to sunset over the course of a year.” The analysis report should also describe measures that the installer will take to eliminate or mitigate effects.



* According to the British Epilepsy Foundation, around 5% of people with epilepsy are likely to experience seizures triggered by flickering or flashing light, but the foundation is not aware of flickering from wind turbines triggering a seizure. Most people with photosensitive epilepsy are sensitive to flickering around 16 to 25Hz, although some people may be sensitive to rates as low as 3Hz (British Epilepsy Foundation, 2006). A current model General Electric turbine has a nominal rotor speed of 10 to 20 rpm, which translates to a blade pass frequency of less than 1Hz. A NEG-Micon wind turbine with a 72-meter rotor diameter and a nominal rotor speed of 17.3 rpm translates to a blade pass frequency of 0.87Hz.

Birds, bats and avian impacts

Virtually all construction on the land is capable of damaging habitat of birds and bats, altering flight patterns and causing mortality. Both the positive and the negative effects of wind power system development should be considered when energy choices are made by power companies, by permitting authorities and by consumers.

Because of the well-documented bird kills caused by some early wind farm installations, concerns are sometimes raised by citizens in local land use meetings about the need to avoid serious avian mortality when siting new windmills. Industry advocates, biologists and bird advocates have said that obsolete, first-generation turbines that were poorly placed have caused an excessive number of avoidable bird deaths. Steps have been taken to minimize avian impacts.

The bird kill problem in the United States surfaced in the late 1980s and early 1990s at Altamont Pass east of San Francisco, where approximately 6,000 turbines were installed on 70 square miles of rolling hills. Within a few years, scientists estimated that several hundred red-tailed hawks and kestrels, and dozens of golden eagles were killed each year by turbine collisions, guy wire strikes and electrocutions (Hoover and Morrison, 2005; Orloff and Flannery, 1992). Biologists suggest that proposals for new wind farms that consider bird migration routes, bird abundance and turbine height will help to minimize fatalities (Desholm and Kahlert, 2006; USFWS, 2005).

Recently, bat scientists estimated that more than 2,000 bats were killed during a one-year period at a wind power facility in the mountains of eastern West Virginia (Kerns and Kerlinger, 2004). Bat mortality at wind turbine sites is currently poorly understood (CBWG, 2006). There are no estimates for wind-power-related bat deaths nationwide.

How many birds die each year?

Scientists provide currently reliable estimates of around two bird deaths per turbine per year outside California (NWCC, 2004; Erickson et al., 2001). (California is an exception because the old Altamont Pass turbines have skewed the data over the years. Many of these outdated installations are being decommissioned.) Therefore, with the current number of installed U.S. wind turbines

U.S. Annual Bird Mortality Comparison - Selected Causes

Causes of bird mortality	2005 estimated annual bird mortality range	2020 estimated annual bird mortality
Hunting by house cats	75 million to 100 million	More than 75 million
Collisions — vehicles	10 million to 60 million	More than 10 million
Collisions — buildings and structures	100 million to 500 million	More than 100 million
Wind power developments	20 thousand to 30 thousand	80 thousand to 120 thousand

Note: This chart, which draws on the latest bird mortality studies, assumes the number of wind turbines will rise fourfold between 2005 and 2020 (a possibility but by no means a certainty).

outside of California standing at between 10,000 and 15,000 units, a current estimate of 20,000 to 30,000 annual wind-power-related bird deaths can be made. It is reasonable to expect a quadrupling of wind system installations during the next 15 years. This would yield an estimate of 80,000 to 120,000 annual wind-power-related bird deaths.

To put this into perspective for local decision makers, independent biologists and the National Audubon Society estimate that house cats kill between 75 million and 100 million birds per year in the United States (ABC, 2006; Malakoff, 2004). One of the greatest risks to birds is plate glass. Windows in buildings kill between 100 million and 500 million birds each year (Klem, 1990). Travel by air and car kills between 2 million and 60 million birds each year (USFWS, 2005; Veltri, 2005).

Future land development will contribute to increased bird-windowpane collisions, bird-automobile collisions and house cat hunting — these are concerns of local officials. Fossil fuel extraction and combustion will also contribute in unquantifiable ways to avian mortality, so a choice must be made by local officials. It should be noted, too, that although wildlife welfare is everyone’s concern, primary responsibility for wildlife management most clearly lies with federal and state authorities under federal and state law.

The new guidelines suggest that local officials take note of avian mortality risks and require an avian and wildlife impact analysis in an application for a utility-scale installation. The analysis should conform to state and federal wildlife agency recommendations based on local conditions.

Local officials are correct to defer to the federal or state government when pressed by citizens to protect birds and bats from construction of wind systems, but they do not have to be silent about the issue. As with air and water pollution, local ordinances may require applicants simply to show that they have obtained “required permits from state and federal authorities” (e.g., the federal Endangered Species Act and Michigan’s Endangered Species Protection Law, P.A. 451 of 1994).

All developments in a community involve trade-offs. Bird safety advocates are correct that wind systems might disrupt habitat and cause mortality. Wind energy advocates note that wind energy provides clean electricity without many of the environmental impacts associated with other energy sources — air pollution, water pollution, mercury emissions and greenhouse gas emissions associated with global climate change. Reducing these environmental impacts by installing renewable energy systems can significantly benefit birds, bats, and many other plant and animal species (NWCC, 2004).

For more information

The Michigan Siting Guidelines for Wind Energy Systems provide local land use leaders with a menu of provisions to select from and offer useful background and guidance to answer some of the questions local officials will undoubtedly hear from neighbors of proposed wind power developments. Contact your county MSU Extension office for more information on land use and wind energy, or find more information online at www.michigan.gov/documents/Wind_and_Solar_Siting_Guidelines_Draft_5_96872_7.pdf.

Michigan's main planning enabling acts are the Township Planning Act (P.A. 168 of 1959), the County Planning Act (P.A. 282 of 1945) and the Municipal Planning Act (P.A. 285 of 1931). Michigan's main zoning enabling acts, adopted in 1921 and 1943, were recently consolidated into a single act (P.A. 110 of 2006) called the Michigan Zoning Enabling Act (M.C.L. 125.3101 et seq.) (MZEA, 2006).



The following states have adopted laws related to wind energy planning, zoning or siting. (The State of Michigan does not have specific enabling legislation for wind facility siting.)

State	Primary Reference
California Government Code	Section 65892.13
Minnesota Statutes of 2006	Chapters 216f and 500.30
Montana Code Annotated	Section 70-17-303
N. Carolina General Statutes	Section 113A-206(3)(b)
Oregon Revised Statutes	Chapter 469.300
Wisconsin State Statutes	Section 66.0401

References

- Aabakken, J. 2005. Power Technologies Energy Data Book (3rd ed.). NREL/TP-620-37930. Golden, Colo.: National Renewable Energy Laboratory. Online at <http://purl.access.gpo.gov/GPO/LPS65772>.
- ABC. 2006. American Bird Conservancy Factsheet: Cats Indoors! Campaign. Online at <http://www.abcbirds.org/cats/downloads.htm>.
- AWEA. 2007. American Wind Energy Association January News. Online at <http://www.awea.org/news/>.
- AWEA. 2006a. American Wind Energy Association December News. Online at <http://www.awea.org/news/>.
- AWEA. 2006b. Wind power myths vs. facts. Factsheet. Online at <http://www.ifnotwind.org/pdf/Myths%20&%20Facts.pdf>.
- British Epilepsy Foundation. 2006. Photosensitive epilepsy – other possible triggers. Living with epilepsy information series. Online at http://www.epilepsy.org.uk/info/photo_other.html.
- CBWG. 2006. Guidelines for assessing and minimizing impacts to bats at wind energy development sites in California. California Bat Working Group. Online at <http://www.wbwg.org/Papers/CBWG%20wind%20energy%20guidelines.pdf>.
- Desholm, M., and Kahlert, J. 2006. Avian collision risk at offshore wind farms. *Journal of Ornithology* 147(Suppl. 5): 156.

- Duke. 2006. Taxing carbon to finance tax reform. Issue brief. Duke Energy and World Resources Institute. Online at http://pdf.wri.org/taxing_carbon_full.pdf.
- EIA. 2006a. Energy Information Administration Factsheet: Average Retail Price of Electricity to Ultimate Customers by End-Use Sector. Online at <http://www.eia.doe.gov/cneaf/electricity/epa/epat7p4.html>.
- EIA. 2006b. Energy Information Administration Annual Energy Outlook 2006 with Projections to 2030. Online at [http://www.eia.doe.gov/oiaf/aeo/pdf/0383\(2006\).pdf](http://www.eia.doe.gov/oiaf/aeo/pdf/0383(2006).pdf).
- EIA. 2005. Energy Information Administration Annual Energy Outlook 2005: Market Trends—Electricity Supply and Demand. Online at <http://www.eia.doe.gov/oiaf/archive/aeo05/electricity.html>.
- EMD International. 2006. WindPro modeling software for turbine siting. Product description. Online at <http://www.emd.dk/WindPRO/Introduction/>.
- Erickson, W., et al. 2001. Avian collisions with wind turbines: a summary of existing studies and comparisons of other sources of avian collision mortality. Report to the National Wind Coordinating Committee, Washington, D.C.
- Fox, B. 2004. Letter to M. Rubin, November 16, 2004. Energy Insurance Brokers. Online at <http://www.power.naturally.org/Programs/Wind/toolkit/icethrowins copy.pdf>.
- Hoover, S., and M. Morrison. 2005. Behavior of red-tailed hawks in a wind turbine development. *Journal of Wildlife Management*, Volume 69, Issue 1 (January 2005), pp.150-159.
- Kerns, J., and P. Kerlinger. 2004. A Study of Bird and Bat Collision Fatalities at the Mountaineer Wind Energy Center, Tucker County, West Virginia. Annual Report for 2003. Mountaineer Wind Energy Center, W.V.
- Klem, D., Jr. 1990. Collisions between birds and windows: mortality and prevention. *Journal of Field Ornithology*, Volume 61, Number 1 (Winter 1990), pp.120-128.
- Klem D., Jr. 2006. Glass: A Deadly Conservation Issue for Birds. *Bird Observer*. Vol. 34, No. 2. Online at <http://www.birdscreen.com/PDF/Bird-Observer 2006.pdf>.
- MacQueen, J.F., et al. 1983. Ice Throw. *IEE Proceedings*, Vol. 130, Pt. A, No. 9, pp. 574-586.
- Madison General Ordinances. 2002. Madison Zoning Code, Sec. 28.04(14).
- Malakoff, D. 2004. Clear & Present Danger. Audubon Society Alert Factsheet. Online at <http://audubonmagazine.org/features0403/alert.html>.
- Michigan Siting Guidelines for Wind Energy Systems. 2005. Michigan Department of Labor and Economic Growth Energy Office. Online at http://www.michigan.gov/cis/0,1607,7-154-25676_25774---,00.html.
- Morgan, C., E. Bossanyi, and H. Siefert. 1998. Assessment of safety risks arising from wind turbine icing. Paper presented at BOREAS 4, April 1998, Pyha, Finland. Online at http://virtual.vtt.fi/virtual/arcticwind/boreasiv/assessment_of_safety.pdf.
- NREL. 1987. Wind Energy Resource Atlas of the United States. Washington D.C.: National Renewable Energy Laboratory, U.S. Department of Energy.
- NWCC. 2004. National Wind Coordinating Committee Factsheet: Wind turbine interactions with birds and bats. Online at http://www.nationalwind.org/publications/wildlife/wildlife_factsheet.pdf.
- NWCC. 2002. Permitting of Wind Energy Facilities. Washington, D.C.: National Wind Coordinating Committee.
- Orloff, S., and A. Flannery. 1992. Wind Turbine Effects on Avian Activity, Habitat Use, Mortality in Altamont Pass and Solano County wind resource areas, 1989-1991. Final report. Sacramento: California Energy Commission.
- Pedersen, E., and K. Waye. 2004. Perception and annoyance due to wind turbine noise: a dose-response relationship. *Journal of the Acoustical Society of America*, 116(6) (December 2004), pp. 3460-3470.
- Rand Corporation. 2006. Impacts on U.S. Energy Expenditures of Increasing Renewable Energy Use. Santa Monica, California: Rand Corporation.
- Sarver, J. 2006. Personal communication. John D. Sarver, Energy Office supervisor, Michigan Department of Labor and Economic Growth. December 2006.

Seifert, H., A. Westerhellweg, J. Kröning. 2003. Risk analysis of ice throw from wind turbines. Paper presented at BOREAS 6, April 2003, Pyhä, Finland. Online at <http://web1.msue.msu.edu/cdnr/icethrowseifertb.pdf>.

Sipe, P. 2006. An Archive of Articles on Wind Energy, Electricity Feed Laws, & Other Topics. Online at <http://www.wind-works.org/articles/index.html>.

Sipe, P. 2005. Wind Energy — The Breath of Life or the Kiss of Death: Contemporary Wind Mortality Rates. Online at <http://www.wind-works.org/articles/BreathLife.html>.

USDOE. 2006. Wind Energy Guide for County Commissioners. Online at http://www.eere.energy.gov/windandhydro/windpoweringamerica/pdfs/wpa/county_commissioners.pdf.

USDOE. 2004. Michigan Wind Energy Resource Maps. Online at http://www.michigan.gov/cis/0,1607,7-154-25676_25774-101765--,00.html.

USEPA. 2006. Frequently Asked Questions About Mercury. Factsheet. Online at www.epa.gov/mercury/about.htm.

USEPA. 1974. Information on Levels of Environmental Noise Requisite to Protect Public Health and Welfare with an Adequate Margin of Safety. Online at <http://www.epa.gov/history/topics/noise/01.htm>.

USFWS. 2005. International Migratory Bird Day Factsheet: Clear the Way for Birds! IMBD Explores Bird Collisions. U.S. Fish and Wildlife Service. Online at <http://www.fws.gov/birds/documents/Collisions.pdf>.

van den Berg, G. 2004. Effects of the wind profile at night on wind turbine sound. *Journal of Sound and Vibration*, Volume 277, Issues 4-5 (November 2004), pp. 955-970.

Veltri, C.J., and D. Klem. 2005. Comparison of fatal bird injuries from collisions with towers and windows. *Journal of Field Ornithology*, Vol. 76, No. 2, pp.127-133.

Reference materials, not cited

Barios, L., and A. Rodríguez. 2004. Behavioural and environmental correlates of soaring-bird mortality at on-shore wind turbines. *Journal of Applied Ecology*, 41 (1), 72-81.

Burkett, E. 2003. A Mighty Wind. *The New York Times Magazine*. June 15, 2003, pp. 48-51.

Cascade Township. 2003. Cascade Charter Township, Kent County, Michigan, Noise Ordinance. Ordinance No. 1 of 2003.

EWEA. 2003. Wind Force 12: A Blueprint to Achieve 12% of the World's Electricity from Wind Power by 2020. European Wind Energy Association. Online at <http://www.ewea.org/index.php?id=30>.

Hoffert, M., et al. 2002. Advanced Technology Paths to Global Climate Stability: Energy for a Greenhouse Planet. *Science*, Nov. 1, 2002:981-987.

Prete, L. 2002. Transmission Pricing Issues for Electricity Generation from Renewable Resources. Online at http://www.eia.doe.gov/cneaf/solar/renewables/rea_issues/transprice_art.pdf.

TrueWind Solutions, L.L.C. 2003. The New England Wind Map. Online at <http://truewind.teamcamelot.com/ne/>.

U.S. Department of Energy. 2006. Wind Energy Guide for County Commissioners. Online at <http://www.nrel.gov/docs/fy07osti/40403.pdf>.

Wind Powering America. 2006. About Wind Powering America. Online at http://www.eere.energy.gov/windpoweringamerica/wind_powering_america.html.

Catalog of Michigan Communities with Wind System						
Planning/Zoning Code Language						
Jurisdiction/Provisions		Noise	Setback	Studies Required Before and/or After	Max. Height	Blade Clearance
Banks Township	Antrim Co.	60 dB(A)	1 x height	Report of soil present on site. Hazard prevention plan.	400'	15'
Billings Township	Gladwin Co.	No adverse impact as determined by Planning Commission.	500' / 1,000'	Documentation regarding wind speed, direction & steadiness. Security and fire plan. Impact assessment.	No adverse impact as determined by Planning Commission	None
Caseville Township	Huron Co.	55 dB(A)	1.5 x height	Site plan. Documentation of sound pressure level and safety requirements being met.	150'	20'
Claybanks Township	Oceana Co.	55 dB(A)	800' 1.75, 1.5 x height	Site plan. Sound impact study.	None	60'
Crystal Township	Oceana Co.	55 dB(A)	Height plus 200 feet	Environmental impact study, noise emission study and written maintenance plan.	400'	20'
Elmwood Township	Leelanau Co.	60 dB(A)	100'	Site plan.	250'	20'
Emmet County		60 dB(A)	1 x height	Site plan. Certification of noise standard.	400'	20'

Michigan Land Use Guidelines for Siting Wind Energy Systems

Jurisdiction/Provisions		Noise	Setback	Studies Required Before and/or After	Max. Height	Blade Clearance
Eveline Township		50 dB(A)	2,600' / 500'	1 year wind resource study. Report of soils present & description of foundation.	230' / 300'	20'
	Charlevoix Co.					
Filer Township		55 dB(A)	1 x height	Site plan. Visual impact analysis. Fire protection plan. Construction plan.	Established in the special use permit.	20'
	Manistee Co.					
Golden Township		55 dB(A)	1.5 x height	Site plan. Sound pressure level report.	Comply with MI Tall Structures Act & local requirement	50'
	Oceana Co.					
Grant Township		55 dB(A)	800 ft or 2 x height. Discretionary in case of wind farm	Wind site assessment for feasibility.	Discretionary	60 ft.
	Newaygo Co.					
Hamlin Township		40 dB(A)	2 x height	Year's data of sufficient wind. Avian study.	None	None
	Mason Co.					
Huron County		50 dB (A) or ambient level + 5 dB(A)	1.5 x hub height, 2 x hub height	Site plan. Avian study. Sound levels. Bi-annual inspection. Decommissioning plan with bond.	275'	75'
Lake Township		60 dB(A)	1 x height	Site plan.	75'	None
	Benzie Co.					
Lodi Township		55 dB(A)	1.5 x height	Site plan. Avian study. Annual inspections. Decommissioning plan.	Subject to provisions of special uses	None
	Washtenaw Co.					

Michigan Land Use Guidelines for Siting Wind Energy Systems

Jurisdiction/Provisions		Noise	Setback	Studies Required Before and/or After	Max. Height	Blade Clearance
Mackinaw City		60 dB(A)	.5 x height	Site plan.	400'	20'
Cheboygan Co.						
Marion Township		50 dB(A)	1.5 x height	Annual wind resources and soil report. Hazard prevention plan. Annual wind production report by month.	400'	20'
Charlevoix Co.						
Mason County		45 dB(A)	2 x height	Site plan. DNR avian data. Wind Rose Chart. Sound chart. Yearly maintenance inspection.	None	30'
Minden Township		55 dB(A) or ambient level plus 5 dB(A)	2 x hub / 1,000	Site plan. Avian analysis. Sound study at "potentially affected existing" buildings	Conditional	50'
Sanilac Co.						
Oliver Township		55 dB(A)	1.5 x height	Site plan. Sound level documentation.	150'	20'
Huron Co.						
Otsego County		Governed by ambient baseline noise study	1,250' / 180' or 1.5 x height	Site plan. Wind resource study. Avian study. Noise analysis. Cost estimate for removal of WTG.	300' / 400'	50'
Suttons Bay Township		60 dB(A)	50' + height	Site plan, visual analysis. Periodic physical inspections.	230'	20'
Oceana Co.						
Whiteriver Township		45 dB(A)	2 x height	Site plan. Environmental study. Financial impact study.	400'	20'
Muskegon Co.						

Glossary*

Airfoil—The shape of the blade cross-section, which for most modern horizontal-axis wind turbines is designed to enhance lift and improve turbine performance.

Ampere-hour—A unit for the quantity of electricity obtained by integrating current flow in amperes over the time in hours for its flow; used as a measure of battery capacity.

Anemometer—A device to measure wind speed.

Average wind speed—The mean wind speed over a specified period of time.

Blade—The aerodynamic surface that catches the wind.

Brake—Various systems used to stop the rotor from turning.

Cut-in wind speed—The wind speed at which a wind turbine begins to generate electricity.

Cut-out wind speed—The wind speed at which a wind turbine ceases to generate electricity.

Furling—A passive protection for the turbine in which the rotor folds either up or around the tail vane.

GWh—Gigawatt-hour, a measure of energy equal to the use of 1,000 megawatt-hours.

Grid—The utility distribution system — the network that connects electricity generators to electricity users.

Inverter—A device that converts direct current (DC) to alternating current (AC).

kW—Kilowatt, a measure of power for electrical current (1,000 watts).

kWh—Kilowatt-hour, a measure of energy equal to the use of one kilowatt in one hour.

MW—Megawatt, a measure of power (1 million watts).

Nacelle—The body of a propeller-type wind turbine, containing the gearbox, generator, blade hub and other parts.

Power coefficient—The ratio of the power extracted by a wind turbine to the power available in the wind stream.

Power curve—A chart showing a wind turbine's power output across a range of wind speeds.

PURPA—Public Utility Regulatory Policies Act (1978), 16 U.S.C. § 2601.18 CFR §292, which refers to small generator utility connection rules.

Rated output capacity—The output power of a wind machine operating at the rated wind speed.

Rated wind speed—The lowest wind speed at which the rated output power of a wind turbine is produced.

Rotor—The rotating part of a wind turbine — either the blades and blade assembly, or the rotating portion of a generator.

Rotor diameter—The diameter of the circle swept by the rotor.

Rotor speed—The revolutions per minute of the wind turbine rotor.

Start-up wind speed—The wind speed at which a wind turbine rotor will begin to spin. (See cut-in wind speed.)

Swept area—The area swept by the turbine rotor; $A = \pi R^2$, where R is the radius of the rotor.

Tip speed ratio—The speed at the tip of the rotor blade as it moves through the air divided by the wind velocity. This is typically a design requirement for the turbine.

Turbulence—Changes in wind speed and direction, frequently caused by obstacles.

Wind farm—A group of wind turbines, often owned and maintained by one company. Also known as a wind power plant.

Yaw—The movement of the tower top turbine that allows the turbine to stay into the wind.

* Adapted from the National Renewable Energy Laboratory Glossary of Terms, 2006.